

ANIMAL RESEARCH PRODUCTS

Clean Bench
Animal Transfer Stations



Welcome to a
comfortable
clean bench.



THE BAKER COMPANY



Underwriter
Laboratories Listed

Animal Research Clean Benches

Comfortable, easily accessible designs make these clean benches ideal for the animal laboratory environment. Designed exclusively for live animal cell culture applications within the animal research laboratory, our clean benches are backed by years of extensive research, customer feedback, and product testing to ensure that you experience optimum productivity, safety, and versatility.



AniGARD® e3



AniGARD® VF



EdgeGARD®

Versatile clean bench animal transfer stations designed with you in mind

- Spacious, easily accessible work areas accommodate a variety of cage sizes and activities.
- Ergonomic design with efficient lighting increases user comfort and visibility.
- Designed for easy movement and maneuverability throughout the laboratory.
- Offers down to ISO Class 4 (Class 10) protection by delivering HEPA-filtered, particulate-free air.
- Blower/motor system extends filter life, minimizing filter replacements and life-cycle costs.

AniGARD® e3 Animal Transfer Station

Vertical-Flow Partially-Recirculating Clean Bench Multi-Sided 4' and 5' Cabinets Energy Efficient Engineered

The AniGARD® e3 combines improved containment and enhanced ergonomics with lower energy requirements to provide you with unrivaled performance and protection. This durable, easily maneuverable animal transfer station features an ergonomically engineered, adjustable work surface and slanted viewscreen for increased worker comfort. Permitting operator access on three sides, the AniGARD® e3 ATS is designed to provide animal protection and particulate control in the laboratory while maximizing productivity and flexibility. The AniGARD® e3 provides ISO Class 4 (Class 10) air cleanliness and was designed to reduce user exposure to allergens.

Designed to Increase Your Productivity

Comfortable user experience

- Slanted viewscreen on three sides of cabinet provides a direct line-of-sight panoramic view of the workspace.
- Well-lit workspace significantly reduces eyestrain.
- Low noise level improves operator comfort and reduces effect of ambient noise on animals.
- HEPA-filtered air throughout the work surface provides ISO Class 4 (Class 10) protection, reducing operator's exposure to allergens.
- 12" knee space opening provides seated access for small procedures.

Ease of use and versatility

- Three-sided work area permits access by multiple operators, facilitating team-based projects.
- 14" high access openings and a flat, spacious work surface allow cages in a variety of sizes to be pulled in and out quickly.
- Hinged viewscreen opens to 21 ¾" for moving large items in and out of the workspace prior to working in the cabinet, allowing greater visibility and access to work area.
- Electric hydraulic lift motor adjusts, allowing a work surface height of 32 ½" to 44" (with 5" casters) to maximize individual comfort.
- Wide tread stainless steel casters for easy maneuverability and movement throughout the lab.
- 25' retractable power cord provides greater range of use without unplugging.
- Optional pull bar provides ultimate portability.



Easily
 Adjusts
 to Meet
 Your
 Needs



Energy Efficient Engineered

The AniGARD® e3 utilizes StediFLOW™, a self-adjusting motor technology that requires less energy, extends filter life, and reduces heat output to the lab without sacrificing performance.

Superior Performance in Cleanliness, Protection, and Containment

- Air Cleanliness – ISO Class 4 at 0.5 micron (Class 10).
- Product Protection – Meets NSF 49 requirements (for biosafety cabinets).
- Allergen Control – Approaches NSF 49 requirements (for biosafety cabinets).
- Minimizes cage-to-cage cross contamination.
- Optional ULPA filtration for increased product and personnel protection.

Baker Builds It Better

Manufactured for durability

- Stainless steel side wall resistant to sterilants and clydox to greatly reduce potential for corrosion.
- Corner rubber bumpers protect the unit and the lab during minor collisions.
- ¼" clear acrylic, scratch-resistant viewscreen.
- Leg stiffeners and large stainless steel casters provide a solid base for the unit.

Designed for easy cleaning and maintenance

- Moveable, two-piece work surface for easy access to spill tray and pre-filter.
- Welded, full perimeter drain pan under the work surface with 1" drain valve catches liquid or spills and protects electrical components.
- HEPA filters are easily accessed at the top of the cabinet.
- Easily removable pre-filter is located below the work surface.
- Designed for easy serviceability including access panels for all electrical components.
- Blower/motor system extends filter life, minimizing filter replacements and life-cycle costs.



Reduced Exposure to Allergens



Durable for Maximum Portability



Direct Access for Simple Cleaning

Exclusive Momentum Air Curtain Ensures Safety

The AniGARD® e3 employs a unique high-velocity momentum air curtain to help ensure product protection and offers personnel protection without restricting access.

This unique airflow design generates a strong air barrier along the perimeter of the work surface, working to prevent room particulates from entering the work area.

A stainless steel diffuser strategically positioned just below the supply filter directs filtered air down the inside of the viewscreen, creating faster airflow compared to the center of the work area.

Perforations along the perimeter of the work surface under negative pressure assist in capturing particulates that are entrained by the momentum air curtain.

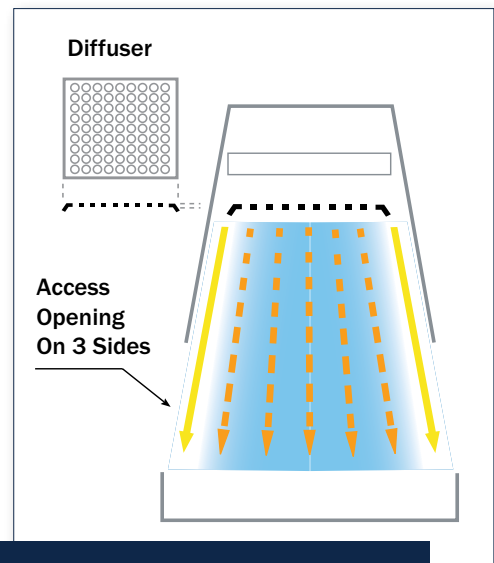

Faster airflow at viewscreen increases protection without restricting access.

Airflow Design Ensures Maximum Protection

The AniGARD® e3 is designed to protect animals from particulate exposure and cross-contamination and reduce users' exposure to allergens by providing HEPA filtration in a partially recirculating air system. Its recirculating air design eliminates air discharge near the floor that could kick up dust and dander from the floor and into the environment.

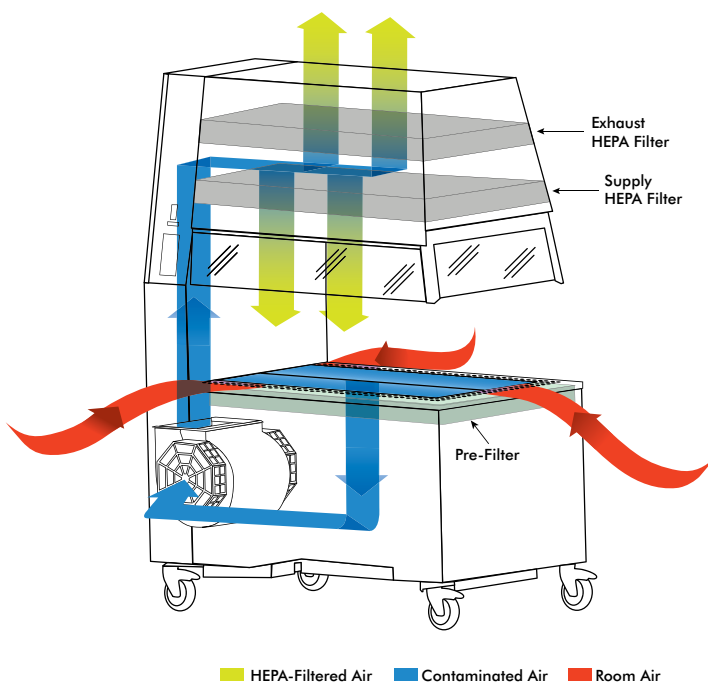

How the AniGARD® e3 Works:

- HEPA-filtered air is delivered to the work area in a vertical downward flow.
- The air passes through a pre-filter located under the work surface, where large particulates are captured.
- A blower forces air through a vertical duct and into the top of the cabinet.
- Half of the air passes through the HEPA supply filter and enters the workspace, and half of the air passes through the HEPA exhaust filter and is released to the laboratory.
- A viewscreen prevents the operator's head from entering the clean air stream.

General Specifications

Performance

- Vertical laminar flow recirculating clean air bench with no discharge near the floor.
- HEPA filters with 99.99% minimum efficiency in capturing 0.3 micrometer particles.
- Provides ISO Class 4 at 0.5 micron (Class 10) for air cleanliness.
- Meets NSF 49 requirements for product protection, and approaches NSF 49 requirements for personnel protection.
- Minimizes cage-to-cage cross contamination.
- Emits low noise level of no more than 59 dBA (AG403) and 62 dBA (AG503), when measured according to NSF method.
- High-velocity momentum air curtain design increases protection.
- Uses a variable frequency drive (VFD) and three-phase motor/blower systems (SteadyFLOW™) that is capable of maintaining a constant air volume as filter resistance increases.

Construction

- Three-sided cabinet with large access opening of 14" high.
- Hinged front and rear side viewscreen opens to 21¾".
- Carbon steel construction with powder coated exterior finish.
- 16-gauge stainless steel work surface, divided into two sections for easy removal.
- Welded, full perimeter drain pan under the work surface with 1" drain valve to catch liquids or spills.
- Easily accessible exhaust and supply HEPA filters located at the top of the cabinet.
- 25' retractable power cord that plugs into standard 15 Amp outlet.
- Electric hydraulic lift system allows the work surface height to be adjusted continuously from 32½" to 44" with 5" casters and from 36" to 47½" with 6" casters.
- Single motor blower for intake air and recirculating air.
- Washable, autoclavable and reusable Scottfoam prefilter located beneath work surface.
- Hinged viewscreen slanted at a 4° angle and fixed viewscreen slanted at a 10° angle for user comfort.
- Separate power switch for light.
- Conveniently located minihelic gauge monitors cabinet operation.
- Comes standard with wide tread casters, 5" diameter with brakes.

Electrical

- Electronic ballast for fluorescent lighting above front and rear access openings.
- Listed by Underwriters Laboratory (UL) for electrical, fire, and personnel safety.

Optional Accessories

- Pull Bar (on open or closed end)
- ULPA Filters
- Carbon Filter (over exhaust)
- 6" Casters with Brakes
- Mouse Corral
- Folding Table
- Light Sensor - automatically turns off the unit's lights when room lights are turned off.
- Viewscreen Magnifier
- 100 V Model (not UL listed)
- 220 V Model



4' and 5' (shown above)
nominal models available.

Dimensions: AG403 with 5" casters

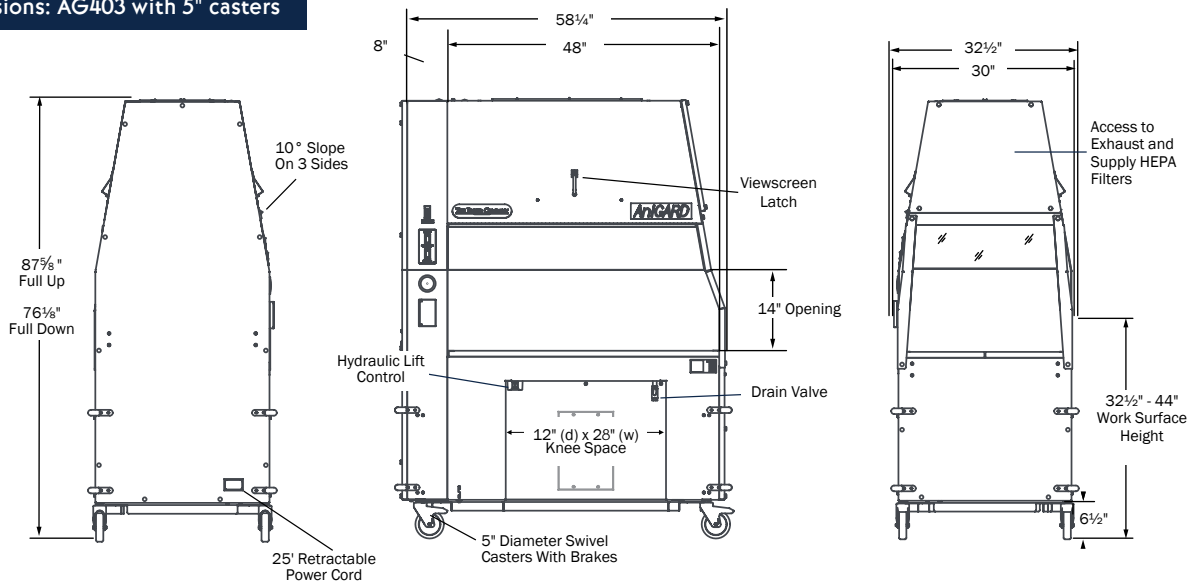

Performance Data

MODEL NUMBER	AG403	AG503
Size	4'	5'
Exterior Dimensions (w x d x h [min to max])	58 1/4" x 32 1/2" x [76 1/8" - 87 5/8"]	70 1/4" x 32 1/2" x [76 1/8" - 87 5/8"]
Interior Dimensions (w x d x h)	48" x 30" x 22 3/4"	60" x 30" x 22 3/4"
Work Surface Height [min to max]	32 1/2" - 44"	32 1/2" - 44"
Usable Workspace (w x d)	42 5/8" x 21 13/16"	54 5/8" x 21 13/16"
Weight	535 lbs.	585 lbs.
Shipping Weight	655 lbs.	720 lbs
Access Opening (working position)	14"	14"
Access Opening (loading/cleaning position)	21 3/4"	21 3/4"
Operating Amperage	3.7 Amps	4.7 Amps
Power Consumption	426 Watts	552 Watts
Heat Generation	1,454 BTU/hr	1,85 BTU/hr
Electrical Requirements	115 V AC, 15 Amps, 60 Hz	115 V AC, 5 Amps, 60 Hz
Noise - NSF Method	59 dBa	62 dBA
Noise - EN Method	57 dBa	60 dBa
Lighting - Minimum average at work surface	100 foot candles	100 foot candles

Note: Data for cabinet with 5" casters

AniGARD® VF Animal Transfer Station

Vertical-Flow Recirculating Clean Bench With Optional Mobile Stand Single-Sided 4', 5' and 6' Models

The AniGARD® VF Animal Transfer Station is a single-sided, vertical-flow clean bench with spacious access for cage changing and protocols where both animal protection and particulate control are required. This ergonomically engineered cabinet features an optional adjustable work surface and slanted viewscreen for increased worker comfort.

Increased Lab Productivity

- 14" high access opening accommodates a variety of cage sizes, and offers a wide work area for multiple users.
- Flat, spacious work surface allows cages to be pulled in and out quickly.
- Hinged viewscreen opens to 30 3/8" allowing access to work area.

Ease of Use and Versatility

- When configured with mobile stand, casters and pull bars, easy to move and maneuver.
- At the lowest adjustment, the unit fits through standard doorways and down laboratory aisles.
- Optional electric/hydraulic lift system positions the work surface elevation at levels from 22" to 40 1/2".

Comfortable User Experience

- Slanted 10° viewscreen for operator comfort and direct line-of-sight viewing.
- Well-lighted workspace reduces eyestrain.
- Low noise level improves operator comfort and reduces effect of ambient noise on animals.
- Provides ISO Class 5 (Class 100) protection by delivering HEPA-filtered air to the work surface.

Baker Builds It Better

- All clean benches are subjected to rigorous testing prior to shipping.
- Primary HEPA supply filter is removed through the front plenum area.
- Designed for easy serviceability, including access panels for all electrical components.
- Rear forklift slots facilitate installation. (Available on lift stand option.)
- Pre-filter below work surface helps capture large particles, prolonging HEPA filter life.
- Unique high-velocity momentum air curtain to help ensure product protection without restricting access.



Performance Data

MODEL NUMBER	AG4-VF	AG-5-VF	AG-6-VF
Size	4'	5'	6'
Exterior Dimensions w/ Stationary Stand (w x d x h [min to max])	53 1/2" x 32" x [89 1/16" - 97 9/16"]	65 1/2" x 32" x [89 1/16" - 97 9/16"]	77 1/2" x 32" x [89 1/16" - 97 9/16"]
Exterior Dimensions w/ Mobile Stand (w x d x h [min to max])	64" x 35 9/16" x [80 15/16" - 97 9/16"]	76" x 35 9/16" x [80 15/16" - 97 9/16"]	88" x 35 9/16" x [80 15/16" - 97 9/16"]
Interior Dimensions (w x d x h)	46" x 23" x 31 3/4"	58" x 23" x 31 3/4"	70" x 23" x 31 3/4"
Shipping Weight	785 lbs.	879 lbs.	974 lbs.
Access Opening (working position)	14"	14"	14"
Access Opening (loading/cleaning position)	30 3/8"	30 3/8"	30 3/8"
Electrical Requirements	115 V, AC	115 V, AC	115 V, AC
Amps / Breaker	16 / 20	16 / 20	16 / 20

General Specifications

- Interior workspace made from 16-gauge stainless steel.
- Better than ISO Class 5 (Class 100) air cleanliness in the workspace.
- Carbon steel construction with powder coated exterior finish.
- HEPA filters with 99.99% minimum efficiency in capturing 0.3 micrometer particles.
- Separate switches for blower and light; if blower is not on, light switch will not work.
- Large, easy-to-read magnehelic gauge confirms cabinet operation.
- Washable pre-filter extends HEPA filter life.
- Optional wide tread, stainless steel casters, 5" diameter x 1 1/4", with brakes.
- One duplex on left-hand side (option for one on right-hand side).

Optional Accessories

- Plumbing: One petcock on right-hand side (option for more); petcock connection choices located on bottom, back and top (channel stand) and on side only for lift stand
- Stationary stand
- Electric/hydraulic lift system
- Edstrom watering unit with gooseneck sprayer

EdgeGARD® Animal Transfer Station

Laminar-Flow Clean Bench
Standard with Casters
3', 4', 5', 6' and 8' Models

The EdgeGARD® Animal Transfer Station is a horizontal laminar-flow clean bench that provides HEPA-filtered airflow across the work area and a particulate-free work surface. This cabinet is ideal for a range of laboratory animal research applications where clean air and product protection are essential.

- Product protection – high-velocity return air slots along the front edge and side walls of the work area provide protection from contaminated backwash.
- Comfortable – all models feature non-glare stainless steel work surfaces and sidewalls.
- Efficient – the HEPA supply filter is 99.99% efficient for 0.3 micrometer particulates.
- Provides ISO Class 5 (Class 100) protection by delivering HEPA-filtered air to the work surface.
- Cost effective – voltage-compensated blower/motor maintains performance, extends filter life.
- Mobility – pull bars and casters ensure easy maneuverability and convenience.



Performance Data

MODEL NUMBER	EG3252-ATS	EG4252-ATS	EG-4320-ATS	EG6320-ATS
Size	3'	4'	4'	6'
Exterior Dimensions (w x d x h)	43 1/4" x 34" x 69 5/8"	55 1/4" x 34" x 69 5/8"	55 1/4" x 34" x 75 5/8"	79 1/4" x 34" x 75 5/8"
Interior Dimensions (w x d x h)	34 1/2" x 22" x 28 1/8"	46 1/2" x 22" x 28 1/8"	46 1/2" x 22" x 34 1/8"	70 1/2" x 22" x 34 1/8"
Net Weight	360 lbs	440 lbs	560 lbs	850 lbs
Shipping Weight	500 lbs	600 lbs	700 lbs	1100 lbs
Electrical	115 V, AC	115 V, AC	115 V, AC	115 V, AC
Amps / Breaker	12/15	16/20	16/50	24/30

MODEL NUMBER	EG5252-ATS	EG6252-ATS	EG-8252-ATS
Size	5'	6'	8'
Exterior Dimensions (w x d x h)	64 3/4" x 34" x 75 5/8"	79 1/4" x 34" x 75 5/8"	103 1/4" x 34" x 75 5/8"
Interior Dimensions (w x d x h)	58 1/2" x 22" x 28 1/8"	70 1/2" x 22" x 28 1/8"	94 1/2" x 22" x 28 1/8"
Net Weight	700 lbs	840 lbs	1000 lbs
Shipping Weight	850 lbs	1000 lbs	1250 lbs
Electrical	115 V, AC	115 V, AC	115 V, AC
Amps / Breaker	16/20	24/30	24/30

General Specifications

- HEPA supply/exhaust filters with 99.99% minimum efficiency in capturing 0.3 micrometer particulates.
- Provides ISO Class 5 (Class 100) protection by delivering HEPA-filtered air to the work surface.
- Removable screen protects HEPA filter.
- Washable pre-filter extends HEPA filter life.
- Hinged panel for easy cleaning.
- Non-glare stainless steel work surface.
- StediVOLT™ motor speed controller adjusts to maintain proper airflow.
- Independent GFCI outlet for safety.
- Casters: 5" diameter x 1 1/2" wide tread.
- Two pull bars.

Optional Accessories

- Isolated motor blower
- Magnehelic gauge

Caution

A clean bench is not designed to protect personnel or the environment from potentially harmful agents. The adequacy of this product for the user's personal safety, as with any clean bench, should be determined by an industrial hygienist or safety officer. Site preparation information, architectural drawings, detailed dimensions and purchase specifications are available.

Warranty

The Baker Company, Inc., expressly represents and warrants all goods (a) to be as specified (and described) in The Baker Company catalogs and literature, and (b) to be free under normal use, service and testing (all as described in The Baker Company catalogs and literature) from defects in material and workmanship for a period of thirty-six months from the invoice date.

The exclusive remedy for any breach or violation of this warranty is as follows: The Baker Company, Inc., will F.O.B. Sanford, Maine, furnish without charge repairs to or replacement of the parts or equipment that proved defective in material or workmanship. No claim may be made for any incidental or consequential damages.

THIS WARRANTY IS EXPRESSLY IN LIEU OF ALL OTHER WARRANTIES, EXPRESSED OR IMPLIED, INCLUDING ANY IMPLIED WARRANTY OF MERCHANTABILITY OR FITNESS FOR A PARTICULAR PURPOSE UNLESS OTHERWISE AGREED IN WRITING SIGNED BY THE BAKER COMPANY. (THE BAKER COMPANY SHALL NOT BE RESPONSIBLE FOR ANY IMPROPER USE, INSTALLATION, SERVICE OR TESTING OF THE GOODS.)

THE BAKER COMPANY

P.O. Drawer E, Sanford, ME 04073 · (207) 324-8773 · (800) 992-2537 · Fax: (207) 324-3869 · www.bakerco.com

AniGARD® and EdgeGARD® are registered trademarks and StediFLOW™ is a trademark of The Baker Company.

© 2012 The Baker Company. All rights reserved.